

TS800

Installation & User Guide



Compatible Equipment

CPA6 OM - Output Module

9040 - Loudspeaker

DC54/58 - Digital Communicator (Stand alone only)

LEC8 - 8 Zone Expander

Overview

Introduction

The TS800 Intruder Alarm control system is provided for domestic and commercial alarm systems conforming to BS 4737: Part 1 1986. There are two versions of the Control Panel:

- (1) The Intruder Alarm Control Panel TS800 is a self contained unit with a 2 x 16 digit backlit liquid crystal display (LCD), a tactile backlit keypad, an internal sounder, its own power supply and connections for a standby battery for operation during a mains failure. In its basic form it will monitor up to eight circuits and can be expanded to monitor 16 circuits when a Local Expansion Card (LEC8) is connected. The system may also be controlled from a Remote Keypad (TS800.REM) if required (up to 4 may be fitted to a system).
- (2) The Intruder Alarm Control Panel TS800R is similar to the TS800 but has no front panel keypad or display hence it requires at least one Remote Keypad (TS800.REM) to control it.

Options

- 1 Local Expansion Card (LEC8): A LEC may be fitted inside the panel and will provide the facility to monitor eight additional circuits so that a total of 16 circuits may be monitored by the panel;
- 2 Remote Keypad (TS800 REM): These units, consisting of a tactile backlit keypad, backlit LCD and internal sounder, are used at a remote location to control the main panel. A maximum of four Remote Keypads may be connected;
- 3 Output Module (CPA6 OM): These units may be connected to the panel and are used to provide an output to a set of LEDs to indicate alarm activations. Each module will provide up to eight zone indications and may be 'daisy chained' if more outputs are required (a maximum of 2);
- 4 Digital Communicator: A Digicom type DC28 or similar may be fitted inside the panel to transfer panel status information to a dedicated Central Station via BT lines:

- 5 Printer: A printer type CPA6.P or other standard RS232 serial printers via a Menvier Security Printer Adapter (MPA) may be connected to provide a printout of 200 log events and system parameters.

Specification

Panel input Voltage:	240V +/- 10% 50Hz
Panel Current Cons.:	75mA (normal); 200mA (In Alarm)
Remote Keypad Current Cons.:	15mA (normal); 35mA (In Alarm)
Battery:	12V 6ah sealed lead acid
Zones:	8 (standard); 16 using a LEC
Auxiliary 12V output:	750mA
Control Panel Dim.:	325 (L) x 265 (H) x 80 (D) mm
Control Panel Weight:	3kg
Remote keypad Dim.:	130 (L) x 130 (H) x 30 (D) mm
Remote keypad weight:	200g
Environment:	0 - 55 deg C

Main PCB Layout

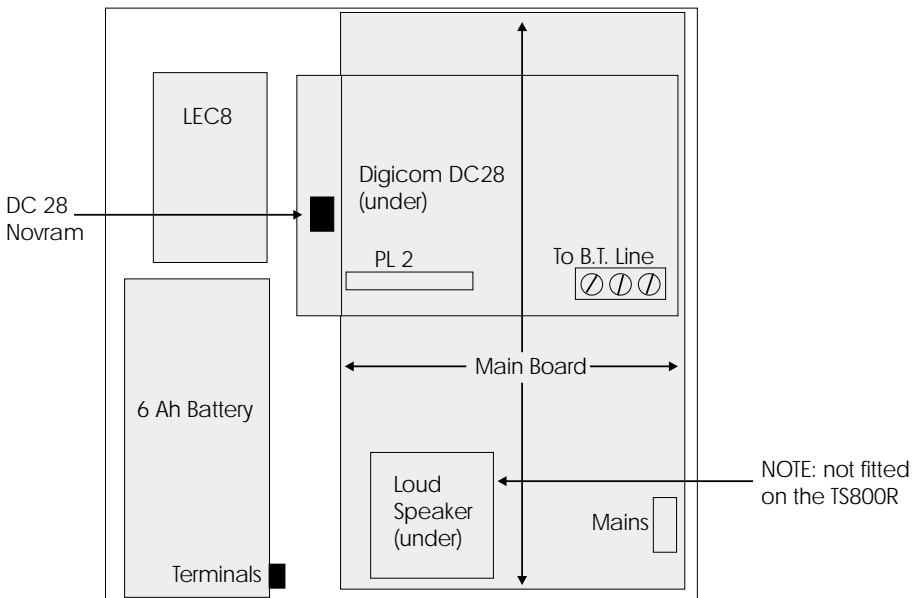

Fig 1 TS800 Panel Layout

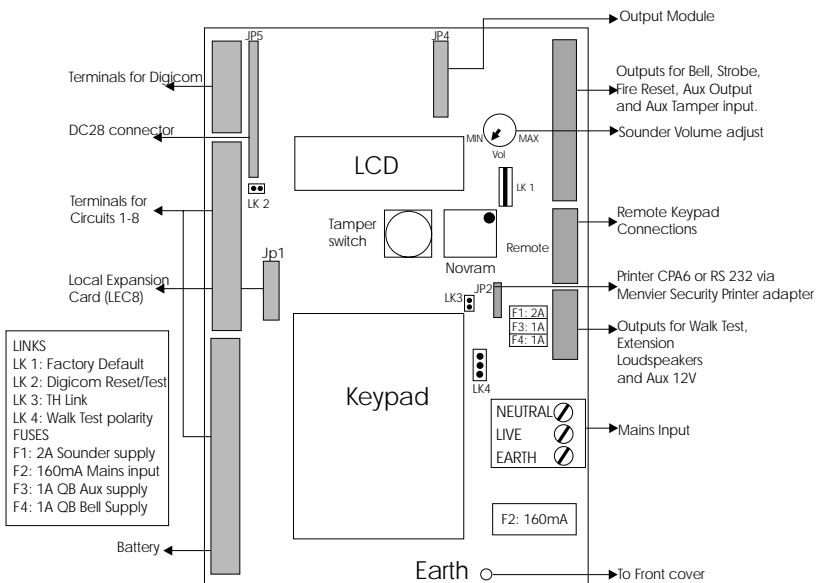

Fig 2 Main PCB Layout

Installing Detection and Tamper Circuits

The Detection circuits may be wired as EOLR (End of line resistor) or DP (Double pole) and the methods may be mixed on the same system.

EOLR System (Fig 3):

- (1) Detector devices have normally closed contacts with a 4k7 shunt resistor;
- (2) Tamper devices have normally closed contacts with no shunt resistor;
- (3) A 2k2 End Of Line (EOL) resistor must be fitted at the point in the circuit furthest from the control panel;
- (4) Loop resistance with the EOL resistor shorted must be less than 100 Ohms;
- (5) The circuit is connected between the upper zone and lower tamper terminals;
- (6) The maximum number of devices allowed in a circuit is ten;
- (7) A normally open device, such as a Pressure Pad or Exit Terminator switch, may also be connected as shown;
- (8) Links can be fitted across the zone and tamper loops if the circuit is not required or may be programmed as SPARE in the DEFINE CIRCUITS menu.

DP Wired System (Fig 4)

- 1) Detector and tamper devices have normally closed contacts in separate loops and are connected to zone and tamper terminals respectively;
- 2) Each alarm loop and tamper loop resistance must be less than 100 Ohms; .
- 3) A maximum of 10 devices may be connected in each loop;
- 4) A normally open circuit, such as a Pressure Pad or Exit Terminator switch, may also be connected;
- 5) Links can be fitted across the zone and tamper loops if the circuit is not required or may be programmed as SPARE in the DEFINE CIRCUITS menu.

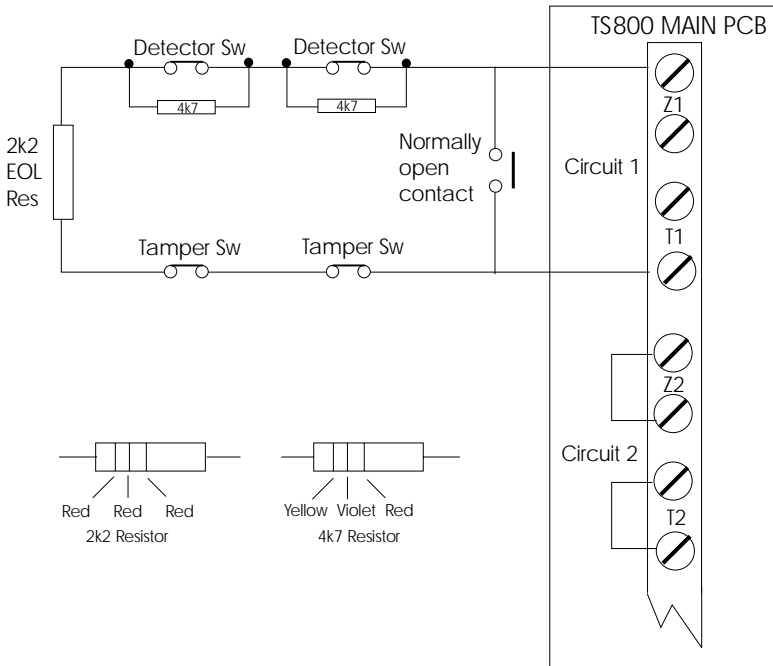

Fig 3 EOLR Circuit Connections

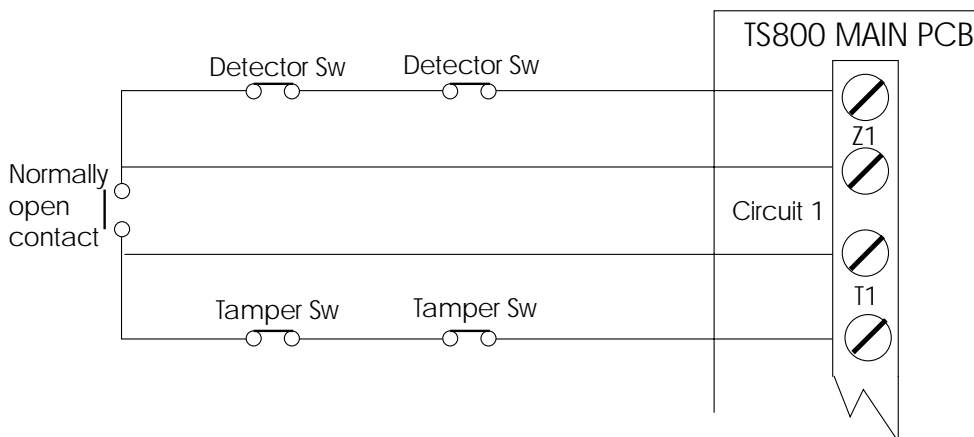

Fig 4 DP Wired Circuit Connections

Installing a Local Expansion Card (LEC8)

If more than eight zones are required then a LEC8 is fitted inside the TS800 case as follows:

- (1) Fit the four posts supplied to the LEC8 PCB then position the LEC in the base and secure it by pushing the posts into the holes provided (Fig 1);
- (2) Fit the connector supplied by connecting it between JPI on the LEC8 and JPI on the Control Panel main PCB (Fig 2);
- (3) Connect the detection circuit cables to the LEC8 (Fig 3 and 4).

Installing Remote Keypads (TS800.REM)

At least one Remote Keypad is required for a TS800R and up to four may be fitted at suitable locations with cables connected to the main PCB 'REMOTE' terminals using 6 core cable (Fig 7):

- (1) In a Daisy Chain configuration in which case the cable length to the last Remote Keypad must not exceed 100m to prevent excessive voltage drop in the cables (Fig 5);
- (2) In a star configuration in which case the cable between the Remote Keypad and Panel must not exceed 100m to prevent excessive voltage drop in the cables (Fig 6);

The PCB is secured to the cover by a screw. The base and cover clip together.

- (1) Open the Remote Keypad case by using a screwdriver to depress two of the retaining clips inwards from their cover indents to release the top or bottom then remove the cover complete with its PCB;
- (2) Secure the Remote Keypad base in its required location using the keyhole and two fixing holes then feed the cable/s through the cable entry, prepare the ends and connect them to the terminal block on the Remote Keypad PCB.
- (3) When all the required Remote Keypads are fitted and cables connected make the connections at the main PCB.

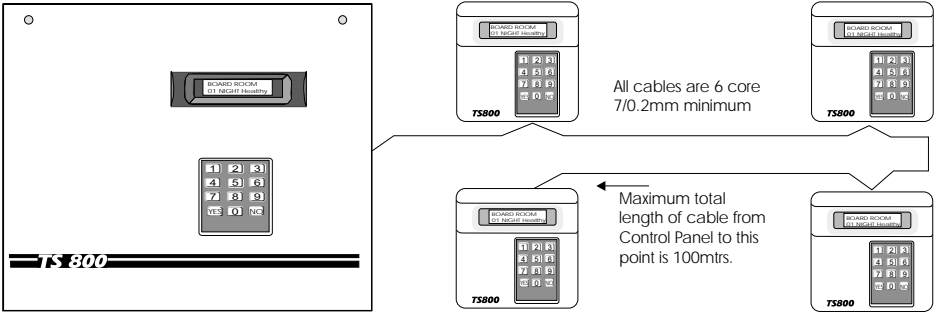

Fig 5 Remote Connection - Daisy Chain Method

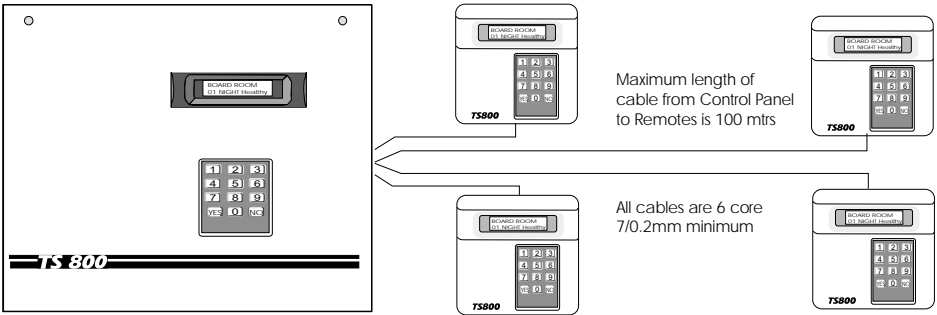

Fig 6 Remote Connection - Star Method

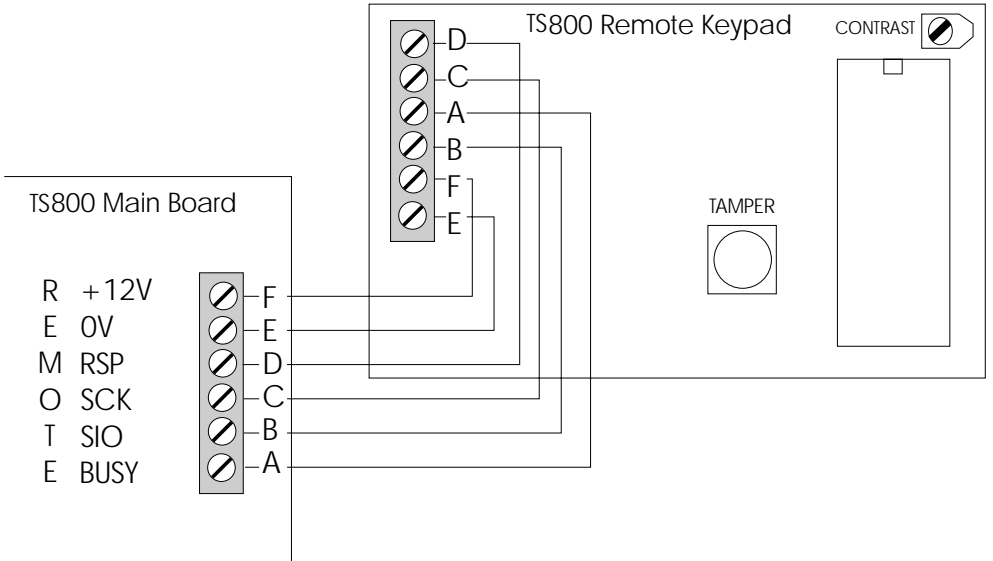

Fig 7 Panel to Remote Keypad Connections

Factory Restart Default Values

When a control Panel is shipped from the factory the memory data default parameters are set to:

- (1) Engineer's Code: 1234;
- (2) Master User's Code: 5678;
- (3) Circuits 01 - 05: Night;
- (4) Circuit 06: Last Exit;
- (5) Circuit 07: Exit Terminator;
- (6) Circuit 08: Personal Attack;
- (7) Circuit 09 - 16: Spare;
- (8) All Circuits in Ward 1;
- (9) Entry Time: 20 seconds;
- (10) Exit Time: 20 seconds;
- (11) Bell Delay: 0 minutes;
- (12) Bell Duration: 20 minutes;
- (13) Double Knock Delay: 0 seconds;
- (14) Part Set Digi Delay: 90 seconds;
- (15) Codes: 4 digit;
- (16) System Reset: By User;
- (17) System Re-arm: Manual;
- (18) PA Alarm: Audible;
- (19) Omitting by: Engineer;
- (20) Full Set by: Circuit;
- (21) Part Set by: Circuit;
- (22) Setting Complete by : Last Exit;
- (23) Quiet Set: N/A;
- (24) Part Set Digi: Instant;
- (25) Algorithm Count: 004.

NOTE:

**IF LINK LK1 IS CLOSED AT POWER-UP,
ALL INFORMATION WILL BE RESET TO THE DEFAULTS SHOWN ABOVE.**

Key Functions

Engineer's Reset

1. Enter the engineer's code default 1234. You are now in Engineer's Mode.
2. Press **[0]** to return to unset.

System Reset

If link LK1, fitted on the Control Panel main board, is OPEN it will ensure that if there is loss of power all the data is retained and this is indicated by the ON SITE RESTART message being displayed on power up. If the link is CLOSED, and there is a loss of power, then all data will be LOST as it will be replaced by the Factory Restart default values. This is indicated by the FACTORY RESTART message when power is restored.

 *Once the system is powered Link LK1 should be opened.*

Preliminary Power Up

To power the system for the first time:

1. Verify that link LK1 on the Control Panel is closed to ensure Factory Defaults are set;
2. Apply mains 240V ac power;
3. Verify that the Control Panel and Remote Keypads display FACTORY RESTART and sounder operates;
4. Enter the engineer's passcode to silence the sounder;
5. Open LK1.

Bell Test/ Walk Test

Please refer to page 10

Engineers Quick Reference

Enter Engineer Code →

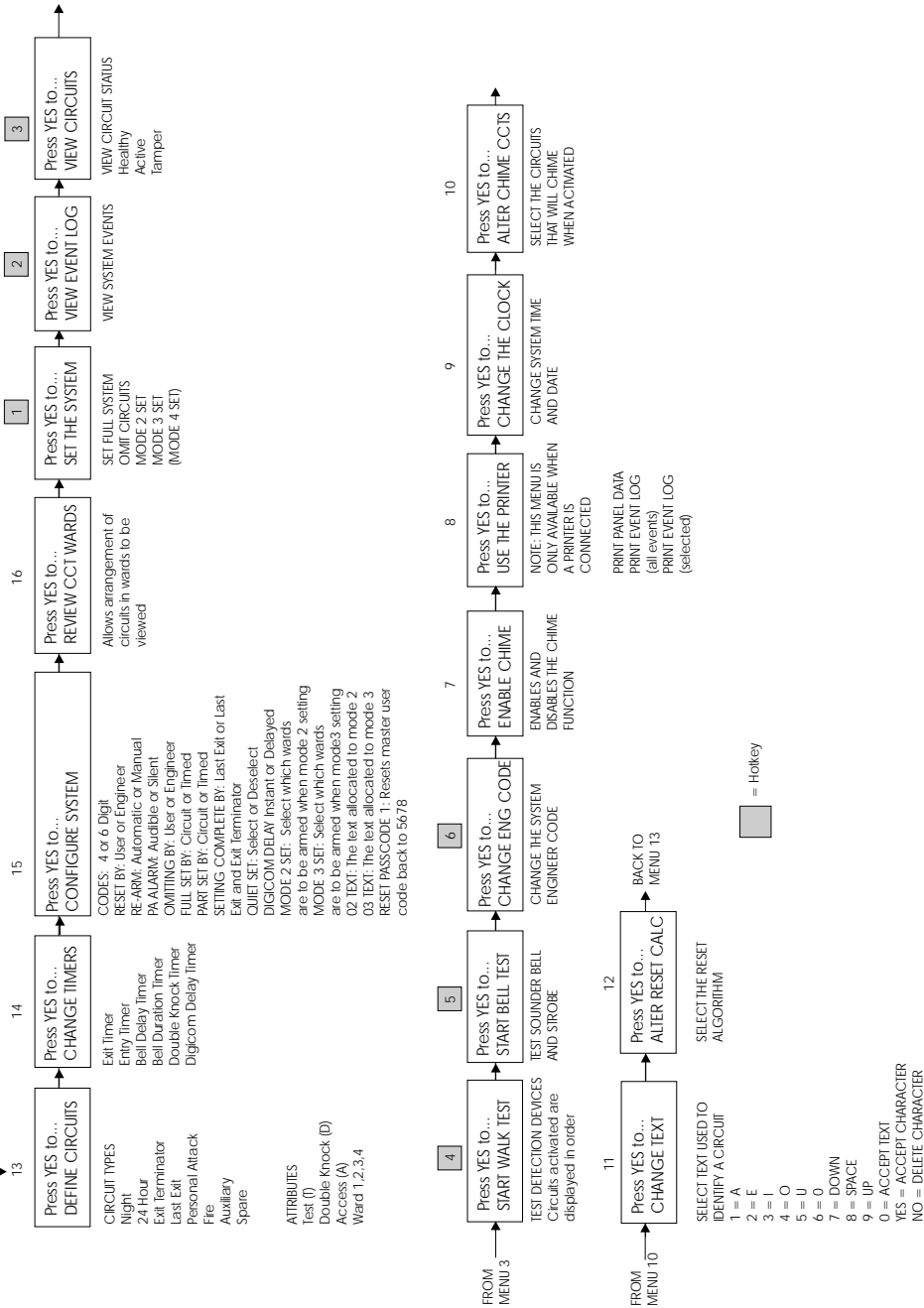

User Programming

Menu No	Menu	Passcode Level
1	Start Set Sequence	0 to 9
2	View Event Log	0 to 7 & 9
3	View Circuits	0 to 7 & 9
4	Start Walk Test	0 to 7 & 9
5	Start Bell Test	0 to 7 & 9
6	Change Codes	1 to 7 & 9
7	Enable Chime	0 & 1
8	Use Printer	0 & 1
9	Change the Clock	0 & 1
10	Alter Chime Circuits	0 & 1
11	Change Text	0 & 1
12	Reset by Code	1 to 7

Notes:

- User 0 is the Engineer
- User 1 is the Master
- User 2 cannot unset Wards 3 and 4
- User 3 cannot unset Wards 2 and 4
- User 4 cannot unset Wards 2 and 3
- User 8 can Set only and is for a cleaner
- User 9 is a temporary (holiday) user
- Menu 8 user Printer only shown if the printer is connected
- Menu 12 only shown if Engineer reset is required

Menus 1 to 6 may be selected directly, after entering a passcode, by pressing the 'hot' keys 1 to 6 as required.